

TL
556
.U.S
T44
NO. 244

Technical Report 244

AD-743288

U. S. Department of Commerce

NOAA

National Climatic Center

LIBRARY

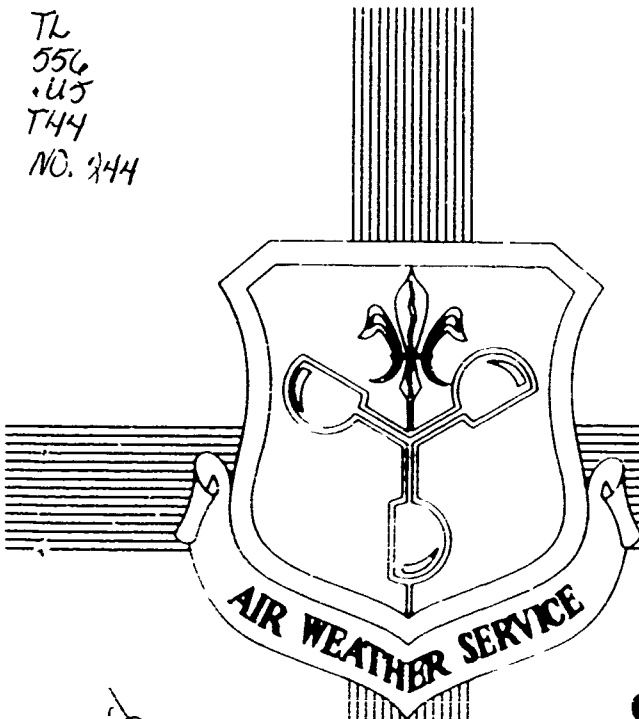

743288

FOURTH ANNUAL SURVEY REPORT ON THE AIR WEATHER SERVICE WEA-MODIFICATION PROGRAM (FY 1971)

By

Herbert S. Appleman
Capt Laurence D. Mendenhall
Capt John C. Lease
Lt Robert I. Sax

Approved For Public Release; Distribution Unlimited.

PUBLISHED BY
AIR WEATHER SERVICE (MAC)
UNITED STATES AIR FORCE

APRIL 1972

DISCLAIMER NOTICE

THIS DOCUMENT IS BEST QUALITY PRACTICABLE. THE COPY FURNISHED TO DTIC CONTAINED A SIGNIFICANT NUMBER OF PAGES WHICH DO NOT REPRODUCE LEGIBLY.

CHANGE

Technical Report 244

July 1972

FOURTH ANNUAL SURVEY REPORT ON THE AIR WEATHER SERVICE
WEA-MODIFICATION PROGRAM [FY 1971]

Air Weather Service Technical Report 244, April 1972, is changed as follows:

1. Make the following change:

Page

Action to be Taken - 8/23/72 OFR

5

Replace Figure 4 with a new figure.

2. After necessary action, file this change in front of page 1, PREFACE.

HERBERT S. APPLEMAN

Senior Scientist

Atmospheric and Space Sciences Directorate

DCS/Aerospace Sciences

DISTRIBUTION: F plus Special

PREFACE

This report is the fourth in a series of annual surveys of the AWS weather-modification program. It describes briefly those projects undertaken during FY 1971, including the techniques, equipment, and results. This report is intended to inform the AWS community of the current status of our rapidly changing capabilities in weather modification. It has not been written to provide the technical details of concern to the weather-modification specialist. Detailed reports on individual projects are published as results warrant and given limited distribution.

HERBERT S. APPLEMAN
Senior Scientist
Atmospheric and Space Sciences Directorate
DCS/Aerospace Sciences

Approved for public release; distribution unlimited.

TABLE OF CONTENTS

	Page
SECTION A — INTRODUCTION.	1
SECTION B — DISSIPATION OF SUPERCOOLED FOG.	2
Ground-Based Seeding with Propane	2
Airborne Seeding with Dry Ice	9
Discussion and Comparison of Results from All Locations	12
Advance Notification and Forecasting Results of Seeding.	13
SECTION C — WARM FOG TEST	14
SECTION D — TEXAS RAIN-AUGMENTATION PROJECT	17
REFERENCES	24

LIST OF ILLUSTRATIONS

Figure 1.	A Typical Propane Dispenser	3
Figure 2.	Dispenser Network at Fairchild AFB, Washington.	3
Figure 3.	Control for Remote Turn-On of Propane Dispensers at Fairchild AFB	3
Figure 4.	Time Cross-Section Showing Results Produced by Seeding Supercooled Fog with Liquid Propane at Fairchild AFB on 18 December 1970.	5
Figure 5.	Dispenser Network at Hahn AB, Germany	8
Figure 6.	The WC-130 Aircraft Employed for Airborne Seeding with Dry Ice	10
Figure 7.	The Dry Ice Crusher/Dispenser in Operation Aboard the WC-130.	10
Figure 8.	European Locations at Which Airborne Seeding with Dry Ice Took Place in 1970-71	11
Figure 9.	Diagram of Liquid Spray System.	14
Figure 10.	Wing Spray Boom	15
Figure 11.	Tail Spray Boom	15
Figure 12.	Solution Storage Area	15
Figure 13.	Map of Runway Complex at McClellan AFB Showing Equipment Locations	16
Figure 14.	Project COLD RAIN Operating Area.	19
Figure 15.	The WMU-1 Catalyst Generator Developed by the Naval Weapons Center.	20
Figure 16.	The Flare Racks with Three Baskets in a "Down" Position Ready for Loading	20
Figure 17.	Installation of the Flares.	20
Figure 18.	The Ready-To-Fly Project.	20
Figure 19.	Photograph of the Kelly AFB CPS-9 PPI Radarscope Taken During a Seeding Operation on 15 June.	21
Figure 20.	Spectacular Cloud Development Followed Seeding Operations on 12 June.	23

LIST OF FIGURES

	Page
Table 1. Field Projects FY 71.	1
Table 2. Results of All Seedings	7
Table 3. Results of Seedings Excluding Cases Where Natural Effects Predominate	7

SECTION A — INTRODUCTION

In early 1967, the Air Force assigned AWS the mission of weather modification in support of military operations. To carry out this assignment, AWS (1) monitors all weather-modification research and development to determine those areas within the scientific state of the art, (2) carries out field tests to make state-of-the-art techniques operational, and (3) applies the resultant techniques in support of actual operations.

Until this year, only the dissipation of supercooled and warm fog has been considered sufficiently advanced to justify AWS field testing. Even so, the warm-fog techniques (except for the costly heat systems and the limited helicopter downdraft procedure) have proved generally disappointing in field tests, indicating the need for further research and development. Consequently, in FY 1971 AWS again invested most of its field testing and operational support in the dissipation of supercooled fog. However, one warm-fog project and one precipitation-augmentation project were also carried out. AWS will continue to monitor the research and development efforts by the scientific community in warm-fog dissipation, precipitation augmentation, hail and lightning suppression, and hurricane modification and, where mutually desirable, will assist such programs within its capabilities.

In FY 1971, AWS carried out a total of six projects — four to dissipate supercooled fog, one to dissipate warm fog, and one to increase precipitation. COLD WAND was a continuation of a FY 1970 ground-based project at Fairchild AFB, Washington. COLD FLAKE was a similar project initiated at Hahn AB, Germany. COLD COWL and COLD CRYSTAL were continuations of airborne projects at Elmendorf AFB, Alaska, and at several USAF bases in Germany, respectively. The warm-fog project was an airborne technique carried out at McClellan AFB, California. COLD RAIN, an airborne precipitation-augmentation project, was operated out of Kelly AFB over southern Texas.

TABLE 1

Field Projects FY 71

Project	Location	Mode	Agent
COLD WAND	Fairchild AFB	Ground-based	Liquid Propane
COLD FLAKE	Hahn AB	Ground-based	Liquid Propane
COLD COWL	Elmendorf AFB	Airborne	Crushed dry ice
COLD CRYSTAL	Germany	Airborne	Crushed dry ice
WARM FOG	McClellan AFB	Airborne	Hygroscopic solution
COLD RAIN	Texas	Airborne	Silver iodide flares

A brief description of the procedures, equipment, and results of these projects is given in the following sections. The theory of fog dissipation and precipitation augmentation is explained in detail in AWSTR 177 (Rev). In brief, cold-fog dissipation relies on creating a multitude of tiny ice crystals in the fog by means of a cooling agent. The ice crystals spread throughout the fog, grow at the expense of the supercooled droplets, and eventually fall to the ground as large crystals or small snowflakes. Since the process takes about 30 to 60 minutes, seeding is generally carried out well upwind of the target area with the resulting clearing being advected over the target by the prevailing winds.

The McClellan warm-fog project relied on falling hygroscopic particles to remove water vapor from the foggy air with resultant evaporation of the fog droplets. The ensuing clearing was projected to form in about 5 to 10 minutes, thus, seeding was carried out immediately upwind of the runway. Finally, the precipitation-augmentation operation relied on seeding vigorous "cumulus congestus" clouds extending to between the -4 and -20°C level with silver-iodide flares. The resultant release of the latent heat of fusion was projected to lead to dynamic growth of the convective cloud mass and the creation of additional precipitation.

SECTION B — DISSIPATION OF SUPERCOOLED FOG

Ground-Based Seeding with Propane (Projects COLD WAND and COLD FLAKE) [1] [2].

Air Weather Service used liquid propane dispensed from the ground as the cooling agent to initiate artificial fog dispersal at two locations in the winter fog season of 1970-71 -- Fairchild AFB, Washington (Project COLD WAND), and Hahn AB, Germany (Project COLD FLAKE). The vaporizing liquid propane cools the air near the dispensing nozzle to below -75°C, causing the formation of multitudes of tiny ice crystals in the fog. These ice crystals spread due to the natural air motion and grow at the expense of the water droplets, eventually falling out as a light precipitation, resulting in an improvement in visibility. Figure 1 shows a typical propane dispenser.

The first AWS propane-dispenser network was established at Fairchild AFB, Washington, in 1968-69. Since that time the network has undergone modification as to numbers and locations of dispensers. In 1970-71 the network consisted of 21 dispensers as shown in Figure 2. Four of the dispensers were equipped to permit remote turn-on and turn-off from the Base Weather Station (BWS) via telephone lines. Figure 3 shows the control box in the BWS. Fans were not used during the 1970-71 winter on the four dispensers so equipped since results during 1969-70 suggested that their use produced little effect.

Operation of the propane system at Fairchild during the 1970-71 winter followed procedures that were essentially routine in nature as contrasted with



Figure 1. A Typical Propane Dispenser. The boom may be lowered for servicing. The one shown here during a test has two nozzles installed, but in normal operation only one is used.

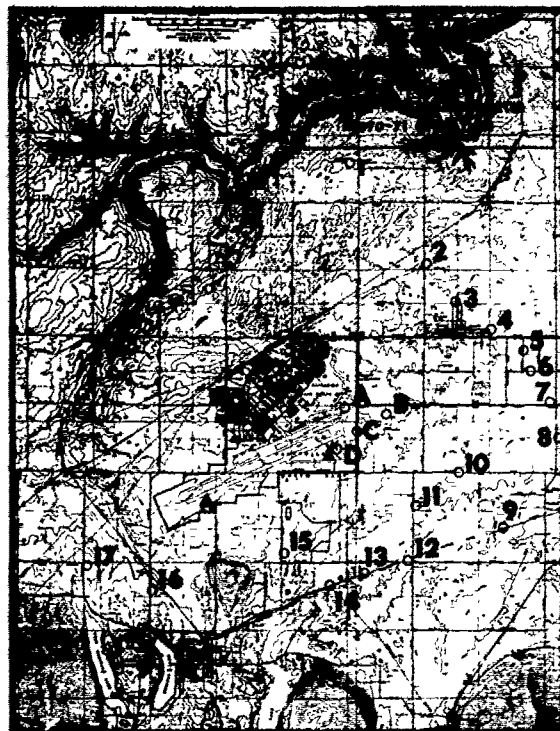

Figure 2. Dispenser Network at Fairchild AFB, Washington.

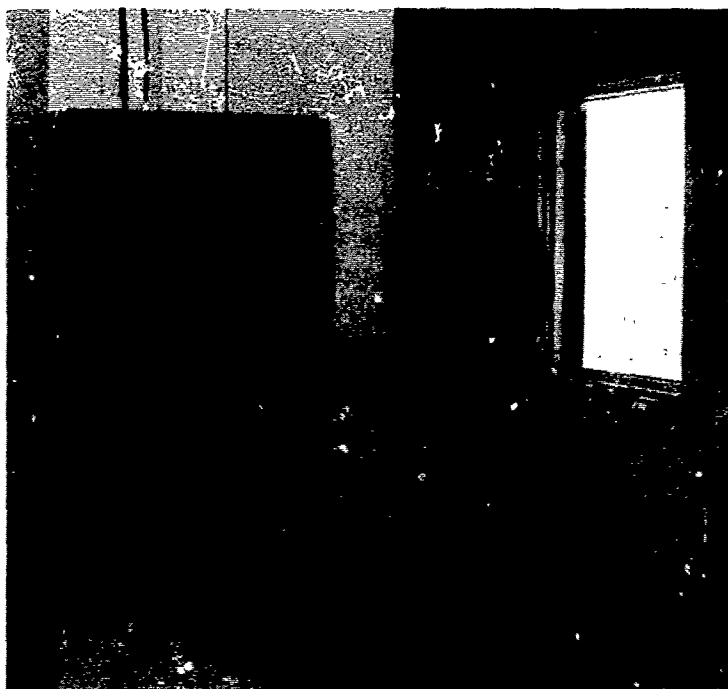

Figure 3. Control for Remote Turn-On of Propane Dispensers at Fairchild AFB. Indicator lights show which dispensers are activated. Only four dispensers possessed the necessary equipment for remote operation in 1970-71, but the console has provisions for additional dispensers.

those procedures followed in previous winters which were designed to produce test data. As a consequence, fewer special observations were obtained than in the past. Colorado State University collected ice-crystal replications during part of the winter. An AN/TMQ-15 wind set equipped with an analog recorder measured the winds atop the control tower while the standard but less sensitive AN/GMQ-11(20) recorded the winds measured at the runway. The transmissometers at each end of the runway were equipped with analog recorders. A dispensing rate of about 10 gallons of liquid propane per hour was used throughout the season. Standard operating procedure called for three dispensers to operate at any given time; which three were determined by the average wind direction during the preceding 30- to 60-minute period. However, in practice, somewhat more than three might operate at a given moment since, if the wind shifted significantly, the new dispensers were activated before the old ones were turned off.

An example of results achieved with ground-based propane-seeding appears in Figure 4. The upper portion of the figure is an exact reproduction of the transmissometer record from runway 23 at Fairchild AFB on 18 December 1970. RVR equivalents for a runway-light setting of 5 appear in the margin on the left. The lower portion, proceeding from top to bottom, shows the time intervals during which the winds should have carried a plume over the runway threshold, the measured ceiling¹, and precipitation. The interval of time from activation of the first dispenser to deactivation of the last dispenser is shown in the upper and lower portions of the figure by a " \longleftrightarrow ." Initially, only dispensers 1 and 3 were turned on but by 0215L dispensers 3 - 7 were operating. Winds atop the control tower, averaged over 60-minute intervals during the period of dispenser operation, ranged from 070°/3.7 knots at the beginning to 055°/2.5 knots at the end. Winds measured by the AN/GMQ-11(20) at the runway indicated dead calm throughout this period. This wind shear explains why the clearing arrived at the runway later than was indicated by the AN/TMQ-15. The apparent shear perhaps also explains why the area of improved visibility passed over the runway continuously while the winds from the AN/TMQ-15 indicated coverage for only two relatively brief periods. The dispensers averaged about 45 minutes upwind from the runway threshold. Conditions were favorable for good results as the temperature ranged near -6°C and the fog was probably not deeper than about 400 feet as evidenced by the lack of a ceiling until near the end of the period.

During 1970-71 only 10 seeding operations took place on 8 different days, the small numbers were due to less than an average amount of supercooled fog. Duration of the seedings varied from 0.5 to 9.5 hours, averaging 3.7 hours.

¹ The ceiling height is measured with a rotating beam ceilometer near the runway threshold while the amount of sky cover and precipitation is observed at the Base Weather Station, approximately one mile east of the threshold to runway 23.

July 1972

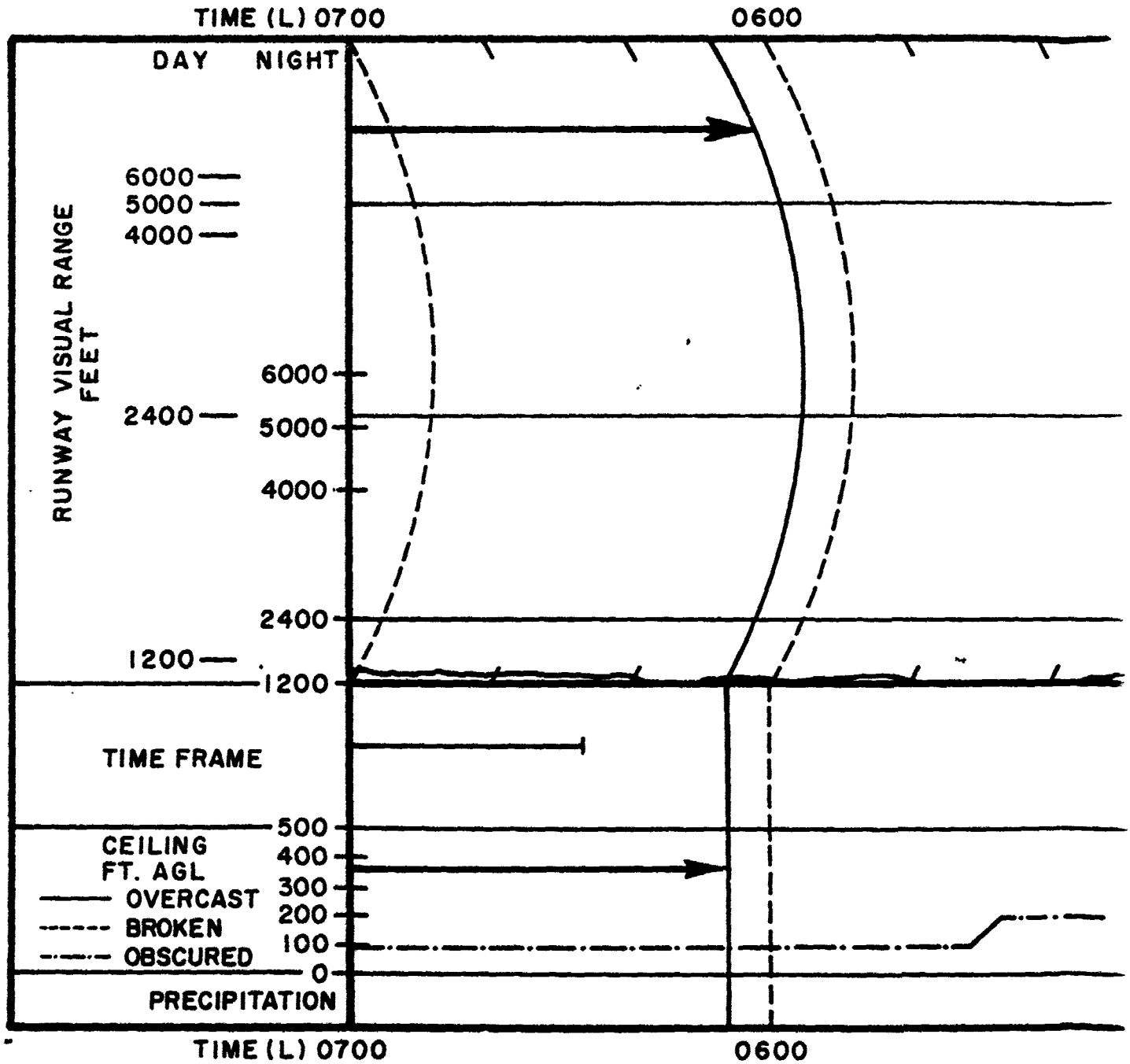

18 DECEMBER 1970

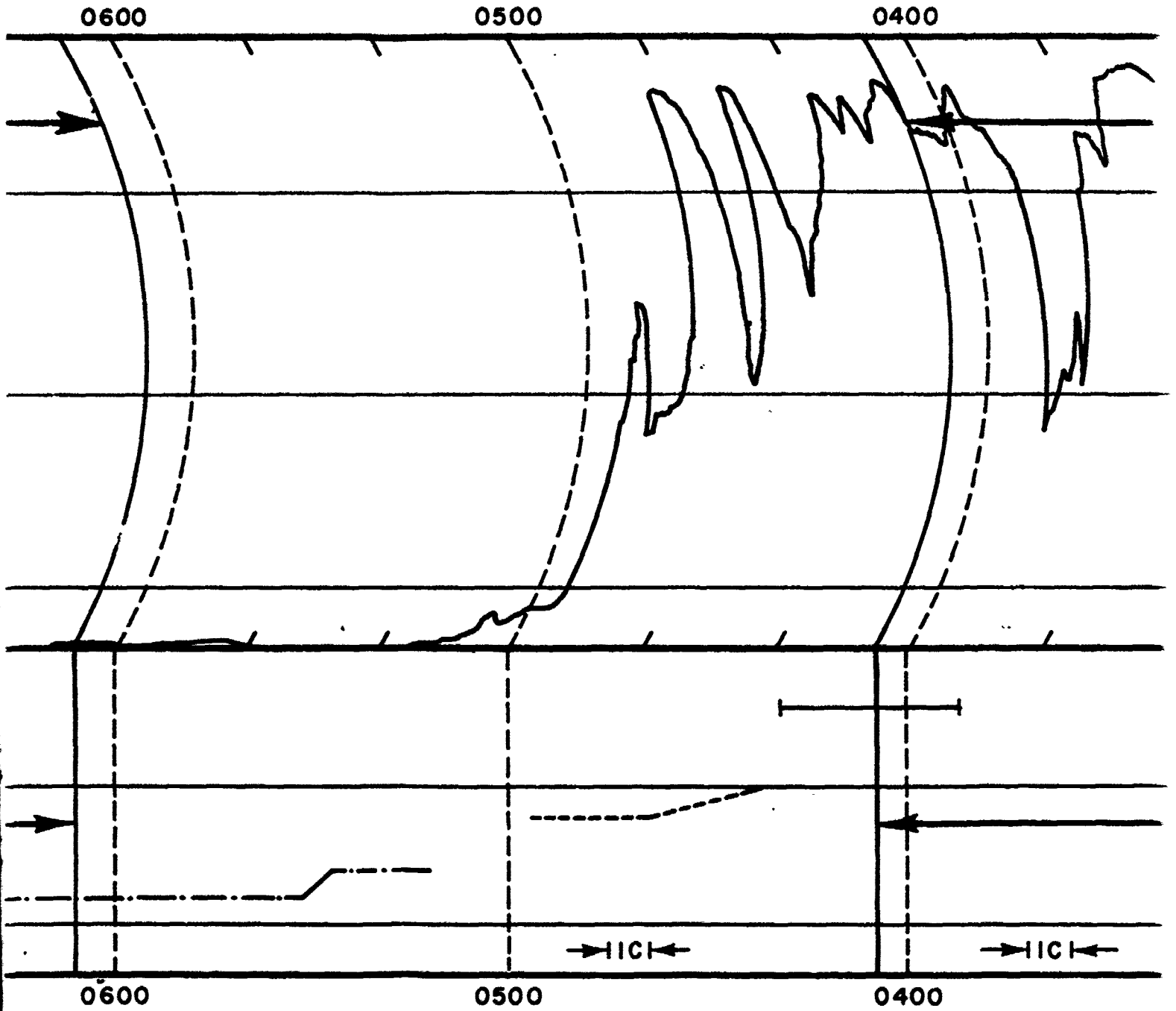

2

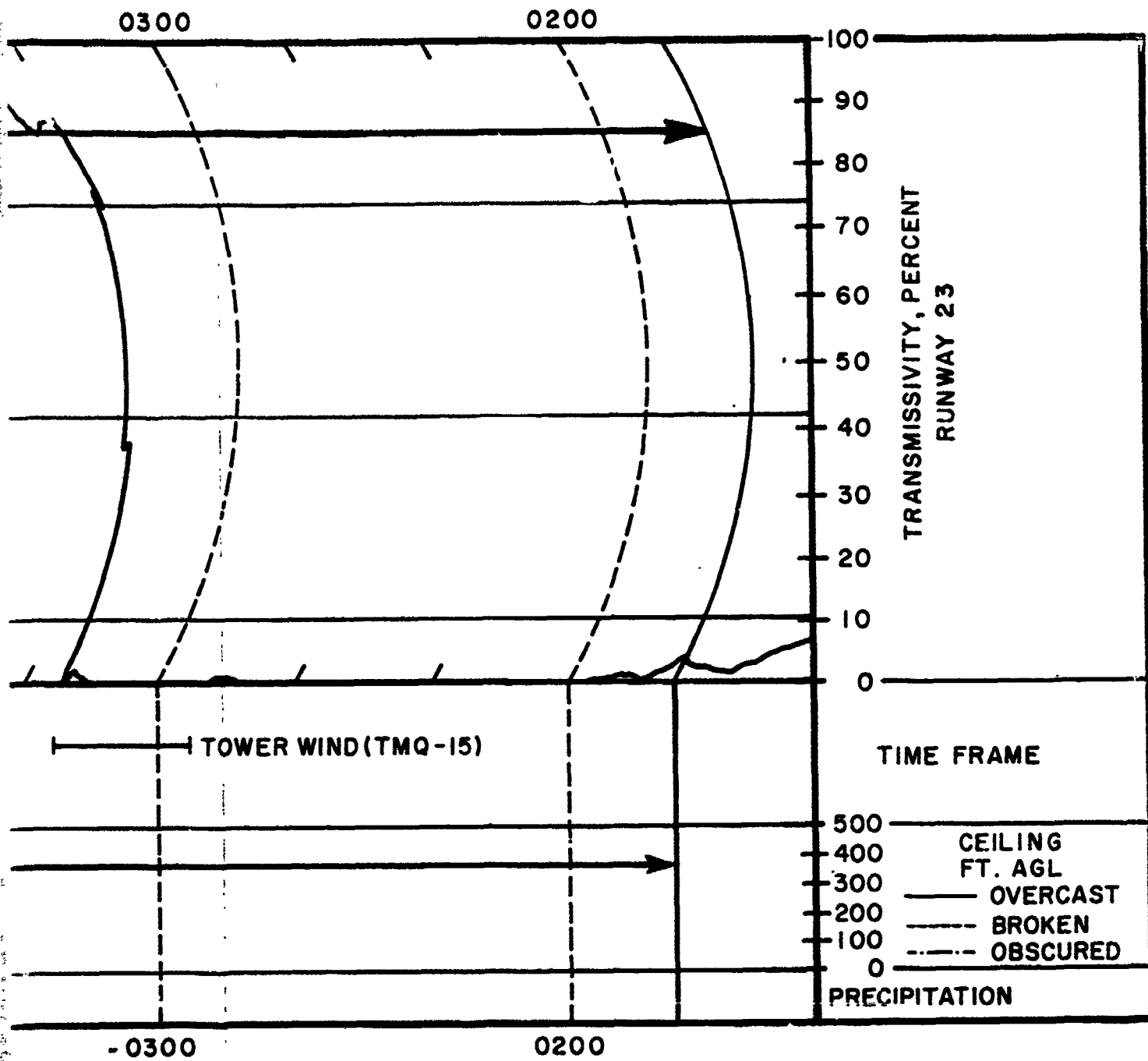

Figure 4. Time Cross-Section Showing Results Produced by Seeding Supercooled Fog with Liquid Propane at Fairchild AFB on 18 December 1970.

3

Seeding covered a total period of 37 hours during the season. During the 37 hours, in the interval from 30 minutes following the activation of the first dispenser until 30 minutes following the deactivation of the last dispenser, the RVR equaled or exceeded 2400 feet an average of 54% of the time. When excluding the four cases in which natural processes likely produced the clearing, the average drops to 41%. Similar statistics for other RVR values appear in Tables 2 and 3. Results of the analysis conducted on the 1970-71 data suggest strongly that some improvement in results could occur by operating more dispensers with the determining condition, the range within which the wind direction fell over the preceding 60 minutes. Such a procedure would allow the wind to vary over a greater range and still have the region of improved visibility hit the runway.

TABLE 2
Results of All Seedings

Project	Total Time Spent Seeding (hr)	Total Time Seeded Area Over Runway (hr)	Average Amount of Time (%) RVR \geq Stated Values		
			Normalized RVR (ft)		
			2400 ²	5000 ²	6000+ ²
			1200 ³	2400 ³	5000 ³
COLD WAND	36.9	36.9	73	54	33
COLD COWL ¹	9.7	45.3	92	83	69
COLD CRYSTAL	71.1	71.0	93	80	34

¹ Excludes the 30 "preventive" seedings ² Night ³ Day

TABLE 3
Results of Seedings Excluding Cases Where Natural Effects Predominate

Project	Amount of Time RVR \geq Stated Values					
	Normalized RVR (ft)					
	2400 ¹		5000 ¹		6000+ ¹	
	1200 ²		2400 ²		5000 ²	
	Total ³	Avg ⁴	Total ³	Avg ⁴	Total ³	Avg ⁴
COLD WAND	15.3	63	10.0	41	3.7	15
COLD COWL	16.1	92	27.2	82	26.8	69
COLD CRYSTAL	29.9	78	36.6	68	15.1	23

¹ Night ² Day ³ Hours ⁴ Percent

² Seeding effects were measured from 30 minutes following the turn-on of the first dispenser until 30 minutes following the turn-off of the last dispenser. RVR converted to daytime values based on a runway light setting of 5.

The second AWS propane system was installed and tested during 1970-71 at Hahn AB, Germany, utilizing a total of 24 manually-operated dispensers. Because wind speeds during supercooled fog range from near calm to over 15 knots, the dispensers appear placed in two arcs, as shown in Figure 5. The relatively rugged terrain in the network, where elevations range from 720 feet (220m) to 1800 feet (550m) MSL, combined with the wind characteristics to produce an operating environment radically different from that at Fairchild.

The first test in supercooled fog at Hahn took place on 11 December 1970, with the last opportunity occurring on 12 February 1971. A total of 14 test seedings took place over a total of 37 hours. Overall results were inconclusive as to the ability of the system as installed to effect clearing at Hahn. However, valuable data on the behavior of the ice-crystal plumes produced by the dispensers and on the wind pattern in the network area provided a basis for specifying new tests in 1971-72.

Two problems prevented testing during all occurrences of supercooled fog with winds from the southeast quadrant. Nozzles were found to clog after operating times of only 15 to 60 minutes. Also restricting the tests was the lack of sufficient operating vehicles to transport dispenser operators. With respect to the first problem, observations revealed that the nozzles clogged due to ice formation inside the dispenser nozzle. Measurements made of the water content of the propane revealed concentrations as high as 2300 ppm (by volume), compared to the US standard maximum allowable of 40 ppm. Since similar clogging had not occurred at Fairchild, it appeared that the excessive water indeed caused the clogging.

The laboratory tests on the first sample of propane obtained from the vendor's supply tanks revealed a water concentration of 580 ppm (by volume). Laboratory chemists suggested the addition to the propane of 20 parts of isopropyl alcohol to each part of water. Assuming the propane tanks in the field contained 580 ppm of water, 4.5 l of isopropyl alcohol was added to each tank. On subsequent tests during February and early March of 1971, nozzles on the dispensers whose tanks contained alcohol did not clog while those without

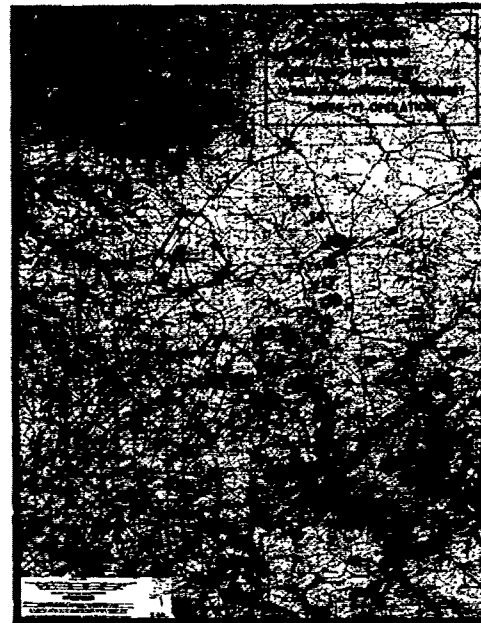

Figure 5. Dispenser Network at Hahn AB, Germany.

alcohol clogged in every case. Thus, addition of isopropyl alcohol to the propane appeared to prevent the nozzle's icing, however, the exact proportion of alcohol to water was not known since samples were not obtained from the tanks in the field.

Airborne Seeding with Dry Ice (Projects COLD COWL and COLD CRYSTAL) [2] [3] [4].

The AWS airborne, supercooled-fog seeding program began with tests conducted at Elmendorf AFB, Anchorage, Alaska, during the winter of 1967-68. Airborne seeding began at several air bases in western Europe in 1968-69. Since the beginning of the airborne seeding program in 1967-68, AWS has flown over 400 seeding patterns. For airborne seeding, AWS utilizes a WC-130 aircraft (Figure 6) equipped with a dry-ice crusher/dispenser (Figures 7a and 7b) and suitable storage for about 6000 lbs of dry-ice slabs. The WC-130 seeds by dispensing the crushed dry ice at rates³ of 10 to 30 lbs/nm in a pattern consisting of a series of parallel lanes spaced 0.5 to 1.5 nm apart and varying in length from 4 to 10 nm. The number, spacing, and length of the lanes depend upon the wind velocity in the fog layer and the desired duration of the clearing over the runway. The dry ice initiates the ice-crystal process which progresses in the manner described earlier for the propane system.

A total of 56 seeding patterns were flown during 1970-71 in COLD COWL. Of these, 30 were preventive; i.e., seeding occurred on supercooled fog remote from the runway when runway conditions were above landing minimums and when the possibility existed that the fog could advect over the runway. In most cases it is impossible to evaluate the results of preventive seeding and, consequently, these 30 cases were not included in the analysis. Of the 26 cases analyzed, it appeared that, for RVR 2400 feet, seeding was primarily responsible for the improvement in RVR in 3 cases, and partly responsible in 10 others, while natural clearing processes predominated in 13 cases. After normalizing all data to daytime RVR 2400 feet, the statistics are 6, 12, and 8 for clearings caused primarily by seeding, partly due to seeding, and primarily by natural processes, respectively. Additional statistics appear in Tables 2 and 3.

COLD CRYSTAL operations in western Europe expanded to include a total of 9 locations⁴ (Figure 8) in 1970-71, compared to only four locations in the first two years. As in 1968-69 and 1969-70, the WC-130 aircraft operated out of Ramstein AB. Support was provided for COLD CRYSTAL from 31 October 1970 to 28 February 1971 by employing up to three WC-130s. Requirements for seeding were levied on Air Weather Service by the 17th Air Force Command Post at Ramstein. If more requirements existed at a given time than available aircraft

³ Because from 20% to 50% of the crushed dry ice consists of particles about the size of fine granulated sugar, which sublimates within the first 100 feet of fall, the effective seeding rate is 20% to 50% less than this when the aircraft flies above the fog top.

⁴ Although authorized, no seeding took place at Wiesbaden AB in 1970-71.



Figure 6. The WC-130 Aircraft Employed for Airborne Seeding with Dry Ice.

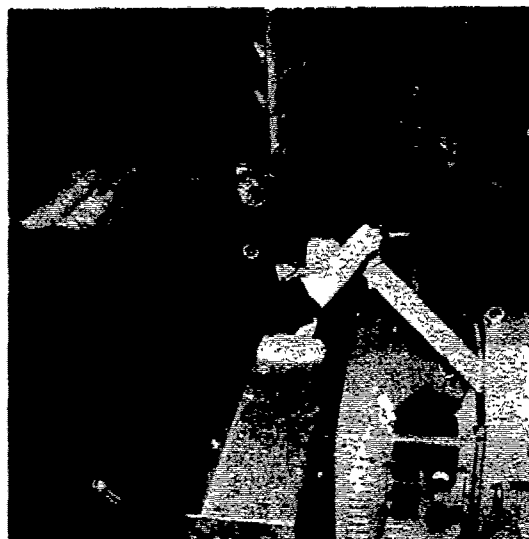

(a)

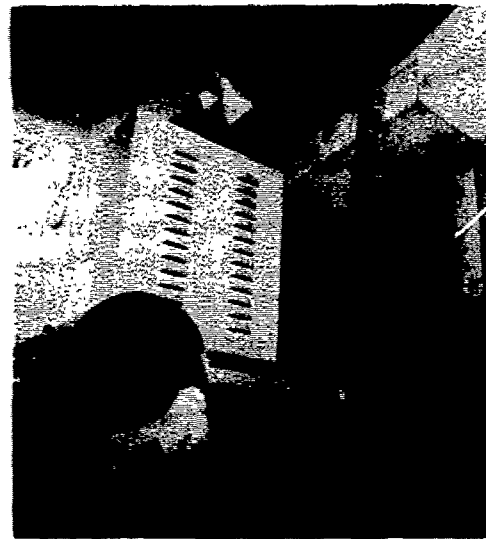

(b)

Figure 7. The Dry Ice Crusher/Dispenser in Operation. Aboard the WC-130.

- (a) Dry-ice blocks stored in cold chests are placed on the tray where crusher operator picks them up for manual feeding to the crusher/dispenser.
- (b) The crushed dry ice feeding from the auger of the dispenser.

could satisfy, which rarely occurred, operational priorities determined by 17th Air Force prevailed. The Duty Coordinator, a fully qualified weather officer, made the final decision as to where and when to seed based on all available meteorological data and on the requirements and priorities established for that day by 17th Air Force.

A total of 51 seeding patterns were flown during COLD CRYSTAL, 25 of these at Hahn AB. When considering an RVR of 2400 feet (day), the improvements in visibility following 20 of these appeared to result primarily from seeding, while in 10 cases, effects from both seeding and natural causes produced the observed improvements. The improved visibilities in 18 cases appeared to result primarily from natural causes. Three cases were not analyzed. The RVR equaled or exceeded 2400 feet (normalized to day scale) 80% of the total possible time when considering all 48 seedings, but this figure drops to 68% when eliminating those cases in which natural effects predominated. Additional statistics appear in Tables 2 and 3.

The support provided to aircraft operations by seeding is difficult to measure. However, the principal measure used at Elmendorf AFB during 1970-71 was the number of aircraft forced to divert because of supercooled fog. During the 1970-71 fog season at Elmendorf, 14 aircraft diverted because of supercooled fog, although four of these diverted because of lack of knowledge of fog dispersal activities. All but one of the remaining 10 aircraft were fighters which do not normally have fuel reserve for holding. The one diversion was a C-141 transport, the most important and frequent user of the base. Otherwise, in the two-hour period following each seeding, a total of 171 aircraft landings and 217 takeoffs were made. However, these figures include all seedings - preventive seedings and those in which natural clearing predominated. Thus, the real significance of these numbers is as an indicator of traffic volume and, thus, an indicator of the potential for diversions or delays since seeding only occurred if aircraft operations were expected. Because of the different nature of operations in the European Theater, aircraft diversions could not be used as a measure of the value of seeding. Following COLD CRYSTAL seedings in 1970-71, a total of 80 arrivals and 155 departures occurred. These aircraft were counted

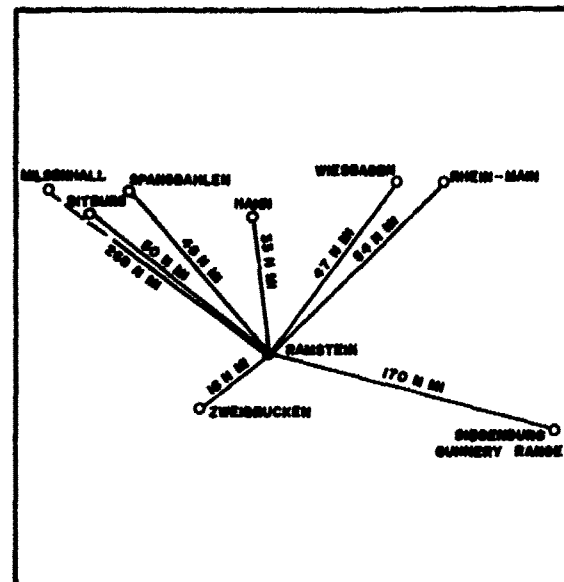

Figure 8. European Locations at Which Airborne Seeding with Dry Ice Took Place in 1970-71. All seeding aircraft operated from Ramstein AB, Germany.

only during the periods in which the seeding effects were affecting the airfield, but did not always exclude those cases in which the improvement resulted from natural causes.

Discussion and Comparison of Results from All Locations.

Tables 2 and 3 give an indication of the reliability with which seeding can produce at/or above minimum RVR values for various RVRs. Table 2 gives the results following all seedings while Table 3 excludes those cases in which natural effects appeared to play a predominant role. The lowest and highest transmissivities observed in each of two 30-minute periods — one immediately preceding the arrival of the seeded volume over the runway and the other immediately following the departure of the seeded volume over the runway — were used to determine if natural effects likely predominated. Clearing following seeding was said to be "natural" if the lowest RVR observed in each of the 30-minute periods exceeded the RVR values in question, or if even the lowest value in the 30-minute period before seeding or in the 30-minute period following seeding exceeded the RVR in question. If the lowest RVR value observed both before and after seeding was less than the RVR in question, it was declared that seeding effects were, at least, partly responsible for the observed visibility improvement, and such cases were included in Table 3. The RVR data appearing in the tables were obtained by converting values of transmissivity, as recorded on analog strip charts, to RVR for runway-light settings of 5. Thus, the threshold value of transmissivity corresponding to an RVR of 1200 feet during the day is approximately the same as that corresponding to an RVR value of 2400 feet at night. The same holds true for RVR pairs of 5000 (night) 2400 (day) and 6000+ (night) 5000 (day)⁵. The average percentages appearing in the two tables come from ratios of the total amount of time that the RVR equals or exceeds the stated values to the total possible time; i.e., the total time the seeded area is over the runway.

Two features in the tables deserve comment. First, in Table 2 for COLD COWL, the "Total time seeded area over runway, hours" greatly exceeds the "Total time spent seeding, hours." This results from the relatively light and variable winds at Elmendorf which permit the seeding aircraft to seed in a few minutes an area of fog that will take the wind several times longer to advect over the runway. In Europe, on the other hand, the stronger winds do not generally allow the aircraft to "gain" much ground. Also, when a seeding pattern misses the runway there is a contribution to the total in the first column but not in the second. Second,

⁵ See Table A3-11B, "Federal Meteorological Handbook No. 1, Surface Observations."

in Table 3, the total hours that the RVR equaled or exceeded RVR 5000 (night)/2400 (day) is larger in both COLD COWL and COLD CRYSTAL than the total hours shown for RVR 2400/1200. This is a consequence of the criteria described in the paragraph above and of the natural variability of the fog. For example, if before or/and after a certain seeding the lowest RVRs exceeded 2400 feet (night)/1200 (day) but did not exceed 5000/2400, the results of the seeding would be included in the latter but not in the former. In COLD COWL, and to a lesser extent in COLD CRYSTAL, RVRs before and after seeding frequently exceeded 2400/1200 but not 5000/2400. The reader should note that the "Total Hours" in Table 3 are hours that the RVRs equaled or exceeded the stated values, and not the total time the seeded area was over the runway. In Table 2 the "Total Hours" corresponding to the percentages shown can be derived simply by multiplying the hours in the "Total Time Seeded Area Over Runway" by the percentages shown. In Table 3, the "Total Time Seeded Area Over Runway" in hours can be computed by dividing the "Total Hours" by the appropriate percentages. However, these will differ for each RVR column for the reasons mentioned above.

It would appear from these tables that seeding with liquid propane at Fairchild AFB (Project COLD WAND) is the least reliable. However, these data do not permit a direct comparison. Whereas, for COLD COWL and COLD CRYSTAL, extraction of RVR data occurred for only those intervals in which calculations using wind data and coordinates of seeded lanes showed the seeded area over the runway, extraction of COLD WAND figures took place for all intervals following seeding. The COLD WAND intervals began 30 minutes after the activation of the first dispenser and ended 30 minutes after turn-off of the last dispenser. In the case of COLD WAND, we are, in effect, assuming that whenever the system is activated, sufficient dispensers are operating to assure that at least one is upwind of the runway approach at any given time. This procedure was followed because of the added complexity of computing trajectories of plumes of individual dispensers compared to that of computing trajectories of lanes. However, examination of the COLD WAND data suggests that little improvement in the statistics would result from employing analytical techniques identical to those applied to the COLD COWL-COLD CRYSTAL data. Nevertheless, the COLD WAND data suggest the realization of a significant improvement in results by simply activating more dispensers at any given time, providing more allowance for the uncertainty in the plume trajectories, and for unexpected shifts in wind direction. Beyond that, the possibility of achieving further improvements would require the addition of more dispensers, thereby decreasing the spacing, and by placing them farther from the runway. Overall reliability of the ground-based system should exceed that of the airborne system simply by virtue of the ground-based system's rela-

tive simplicity. Overall reliability of the airborne system must include the probability of the aircraft failing to take off on schedule or aborting its mission due to maintenance or other reasons once airborne. Available evidence suggests that the quality of the results, once seeding actually occurs, obtained from the ground-based system equals or exceeds that obtained by airborne seeding with dry ice.

Comparison of results obtained in COLD CRYSTAL with those obtained in COLD COWL reveal relatively small differences in the ability to achieve daytime RVRs of 1200 feet and 2400 feet (or nighttime RVRs of 2400 feet and 5000 feet), but a significantly smaller ability to achieve an RVR of 5000 feet (day) in Europe than in Alaska (see Tables 2 and 3). The exact reasons are unknown. However, one factor that probably plays an important role is the presence of considerable industrial pollution in the air at nearly all of the European locations. Indeed, it is rare in the winter for visibilities to exceed 3 miles in Europe on "good" days, while visibilities in excess of 10 miles are common at Elmendorf AFB.

Advance Notification and Forecasting Results of Seeding.

Accounting for the effects of seeding in the preparation and dissemination of the terminal forecasts further enhanced the value of this weather service. Whenever the terminal forecast called for below minimum conditions in supercooled fog and fog-dispersal operations were planned, a second part of the forecast described conditions expected as a result of seeding and the periods of time that seeding would occur. Also, remarks attached to the end of the hourly surface-weather observations transmitted over the weather-communications circuits stated actual beginning and ending times of seeding as well as planned seeding times. To aid further in flight planning, an announcement of the availability of fog-dispersal service appeared in the Flight Information Publication, "Enroute Supplement," for Elmendorf.

SECTION C — WARM FOG TEST

Throughout the world, warm fog occurs far more frequently than cold fog. Consequently, it is of greater concern to the Air Weather Service. The problem of warm-fog dissipation is, however, far more difficult. Research and development efforts are going on in the United States and abroad, but so far little success has been achieved. The French have recently installed a promising system at Orly Airport near Paris using the exhaust heat from eight underground jet engines vented over the approach end of the runway. AFCRL and the Army have jointly tested the use of helicopter downwash to cut holes in shallow fogs. This technique has proved successful under favorable conditions. Hygroscopic salts and solutions dispensed from the ground or from aircraft have been tested by several agencies in an attempt to produce clearings by drying the air and evaporating the fog droplets. The Naval Weapons Center (NWC) has conducted tests that have reportedly shown some success using an aqueous solution of ammonium nitrate and urea. The results suggest that a test in an operational environment should be conducted to determine if such a technique could serve as a basis for an operational fog-dissipation capability.

Air Weather Service designed an operational test to be conducted at McClellan AFB during January 1971. The tests were conducted to evaluate the effective-

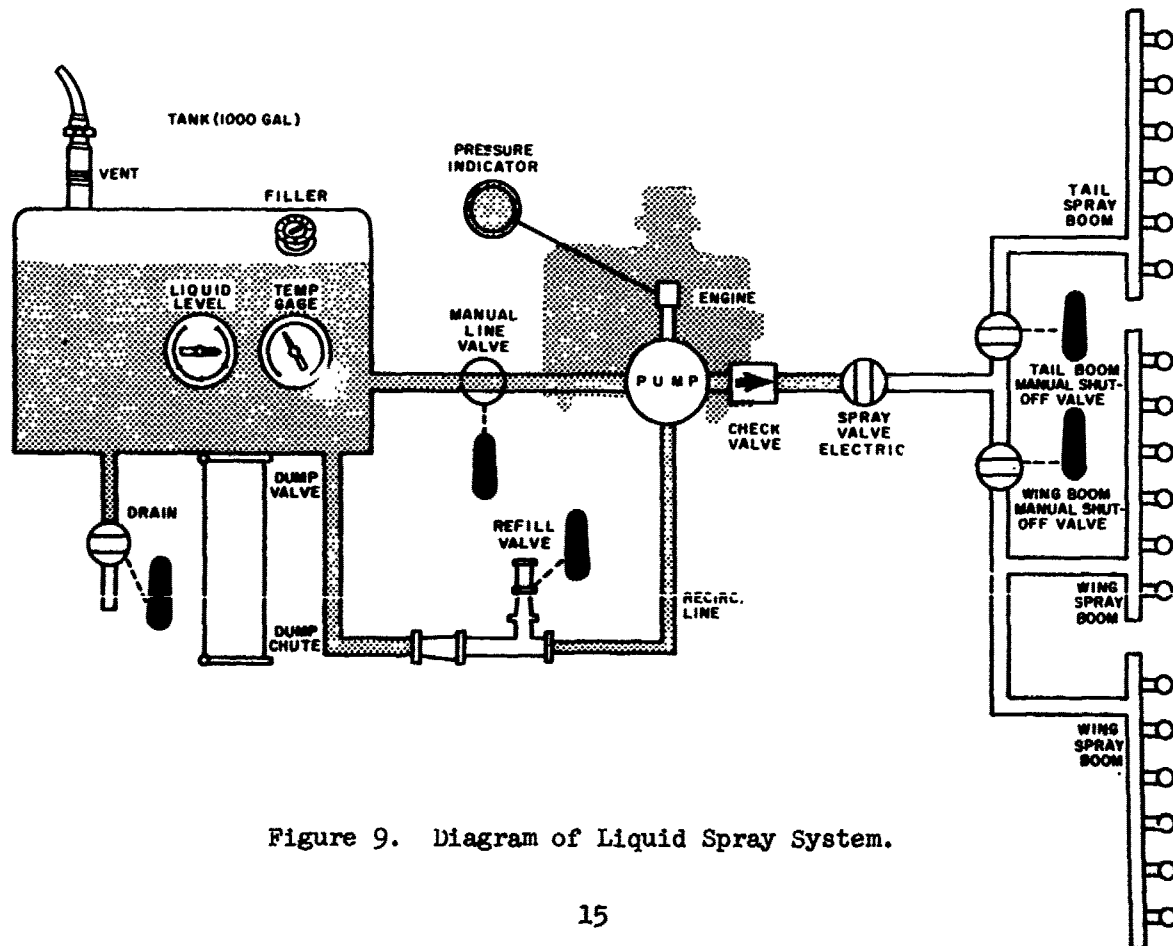

Figure 9. Diagram of Liquid Spray System.

ness of an aircraft-dispensed aqueous solution of ammonium nitrate and urea for improving the visibility in the runway approach to Category I (RVR 2400 ft) and Category II (RVR 1200 ft) minimums when fog is restricting visibility.

Two Tactical Air Command UC-123K aircraft, equipped as spray platforms, served as the seeding aircraft. The spray system (Figure 9) was capable of delivering 1000 gallons of solution at a rate of 100 to 400 gallons per minute through externally-mounted spray booms located under each wing (Figure 10) and under the aft section of the fuselage (Figure 11). The solution was released from agricultural spray nozzles with the restricting orifices removed to allow higher flow rates.



Figure 10. Wing Spray Boom.



Figure 11. Tail Spray Boom.

The solution used for seeding consisted of four parts ammonium nitrate, three parts urea, and 0.78 parts water by weight. It was stored in a 10,000 gallon insulated tank (Figure 12), obtained on loan from the Naval Weapons Center. Since the solution would become saturated and start to salt out at temperatures below 70°F, the temperature was maintained at 100 to 110°F by three immersion heaters.

Air Force Cambridge Research Laboratories (AFCRL) made additional weather instrumentation available to Air Weather Service to supplement the equipment already installed at McClellan AFB. This additional instrumentation consisted of two low threshold-of-response



Figure 12. Solution Storage Area.

wind sensors and two transmissometers. The location of the equipment is shown in Figure 13.

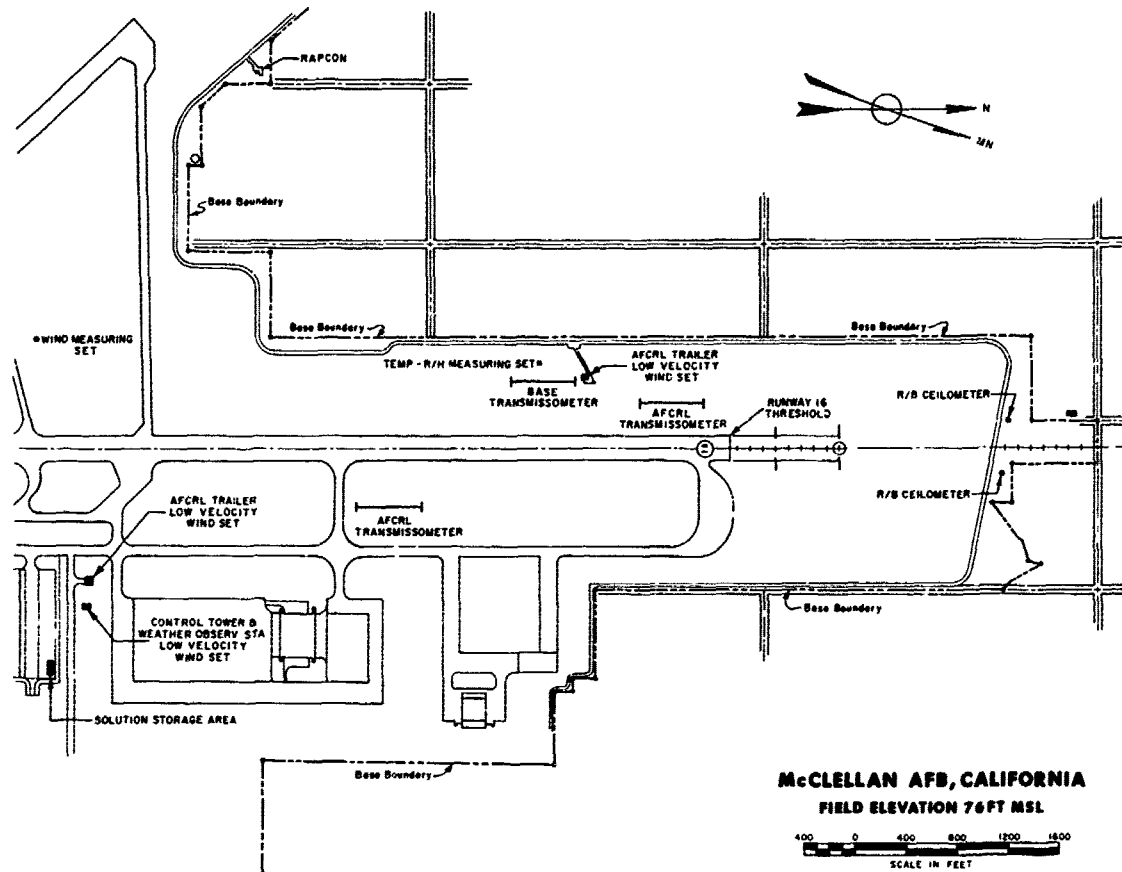

Figure 13. Map of Runway Complex at McClellan AFB Showing Equipment Locations.

The seeding pattern consisted of two aircraft flown in trail, offset upwind of the approach corridor centerline a distance equal to seven minutes of wind drift. All seeding passes were made at 400 feet above ground level at an indicated air speed of 125 knots. This information, along with estimates of the size distribution of the seeding material and the width of the seeded volume produced by the seeding aircraft, were run with AF'CRL's warm-fog computer model. This produced estimates of the amount of material that would be required to produce clearings of the magnitude desired and the time required to attain maximum clearing. The computer model predicted that a seeding rate of 500 gallons per minute per aircraft would be required to produce a clearing with a visibility of one-half mile in six to eight minutes.

Seven separate seeding operations were conducted during the test period,

two on 25 January and five on 27 January 1971. The tests conducted on 25 January started at 0945 local time. Natural clearings began at approximately the same time, so that any results that might have been produced by seeding were obscured. On 27 January, the tests began at 0400; the prevailing visibility remained at 1/16 mile or less throughout the test period. There were no detectable improvements in visibility on any of the transmissometers following any of these five tests.

The wind information from all available wind sensors was analyzed to estimate the drift of the seeded volume of fog in all cases. It was found that due to wind fluctuations most of the seeded fog did not drift over any of the transmissometers in the desired 6 to 10 minute time frame following seeding. In only one case did the analysis show that the seeded volume of fog should have been over the area of the transmissometers in the time frame desired. Predicting the winds in the fog was the most difficult problem encountered during the program. Calm winds were rarely encountered in a fog situation; in fact, winds were seldom less than the 2 to 3 knots as measured by the low threshold-of-response wind sensors. When the winds were less than 2 knots, they were characterized by wide variation in both speed and direction over short-time intervals.

The small number of tests conducted and the difficulties experienced in predicting the drift of the seeded volume of fog due to the variability of the winds, made it impossible to evaluate the effectiveness of the ammonium nitrate/urea solution in fog dispersal. However, the technique proved an operational failure based on the tests carried out. Because of the relatively small volume of fog that can be seeded by an aircraft, the importance of properly targeting the seeded volume upwind of the runway is paramount. It was found at McClellan AFB that the Precision Approach Radar (PAR) is capable of positioning the seeding aircraft within 25 to 50 feet of the desired location out to 1000 feet to either side of the runway centerline. It quickly became evident, however, that the accuracy of the PAR radar could not be put to effective use since it was not possible to make the short-term wind forecasts necessary to know where the aircraft should be placed during the seeding run. It is mandatory, therefore, that further investigations be conducted into the small-scale wind fields that exist in warm fog, as the success of this technique, and perhaps all others, to dissipate warm fog will depend upon the ability to predict these winds accurately. The only other option for hygroscopic material is to develop a delivery system that can adequately seed so large a volume of fog that the small-scale variations in the wind field no longer have a significant effect.

SECTION D — TEXAS RAIN-AUGMENTATION PROJECT (COLD RAIN) [5]

Since the discovery in the late 1940s of the ice-nucleating properties of

dry ice and silver iodide, cloud physicists have been attempting to augment rainfall by upsetting the delicate metastable balance of microphysical forces which exists in clouds containing water in a supercooled liquid state. Two theoretical approaches to increasing precipitation by seeding supercooled clouds with silver iodide (AgI) have been advanced. One method relies upon broadening the droplet spectrum to initiate the coalescence process through the Bergeron-Findeisen preferential growth of ice with respect to water in a mixed-phase cloud. The induction of such colloidal instability is often termed "static seeding" because only enough ice nuclei are introduced to alter the cloud microphysics.

The alternative approach is to introduce a large enough quantity of ice nuclei to affect the dynamical cloud circulation. During the water-to-ice conversion process, about 80 calories of fusional heat are released to the environment for every gram of water frozen. Once some ice crystals have formed within a cloud, the direct deposition of water vapor onto the crystal surfaces results in additional heating. The total heat released may be sufficient to increase greatly the buoyancy of the cloud body and cause it to grow both vertically and horizontally. Such growth can be pronounced, even spectacular, if a weak stable layer (inversion) is capping natural cloud development. In theory, the resulting larger cloud mass will have a much longer lifetime and be so much more efficient at processing the available moisture that rainfall can be significantly increased over what would occur from a series of relatively shallow, poorly-organized, unseeded clouds. This approach to rain augmentation is termed "dynamic seeding" and is primarily applicable to supercooled convective (cumulus) clouds. This type of seeding has been used with some degree of success both by the Navy and Air Force in the Philippine Islands [8], and by the National Oceanic and Atmospheric Administration in the Caribbean [7] and in Florida [6]. A climatological survey of the supercooled convective-cloud activity occurring in south Texas during the month of June 1971 indicated that the utilization of the dynamic seeding approach would offer a good chance of augmenting rainfall in that area.

Project COLD RAIN was the designation given to the Air Force portion of a Bureau of Reclamation-directed, operational rain-augmentation program designed to help alleviate the severe drought conditions which existed throughout the south-central Texas area during the spring of 1971. Commencing on 6 June and continuing until the project terminated on 30 June, two Air Weather Service WC-130/B aircraft, specially equipped to deliver and release pyrotechnic flares containing silver iodide nucleating material, carried out a total of 35 cloud-seeding missions involving 157 hours of flying time. More than 1000 seeding penetrations were made into more than 250 individual cumulus towers; 2671 flares, each distributing 25 grams of silver iodide, were expended.

COLD RAIN was staged from Kelly AFB (SKF) near San Antonio. The area outlined in black in Figure 14 was the region of Texas subjected to Air Force seeding operations at one time or another during the duration of the project.

The primary, most intensively, seeded area is shaded. The hatched region represents an area seeded jointly by the Air Force and by private contractors hired by the Bureau of Reclamation. The total operating area was quite extensive, encompassing approximately 75,000 square nautical miles. The area intensively seeded comprised about 25% of the total.

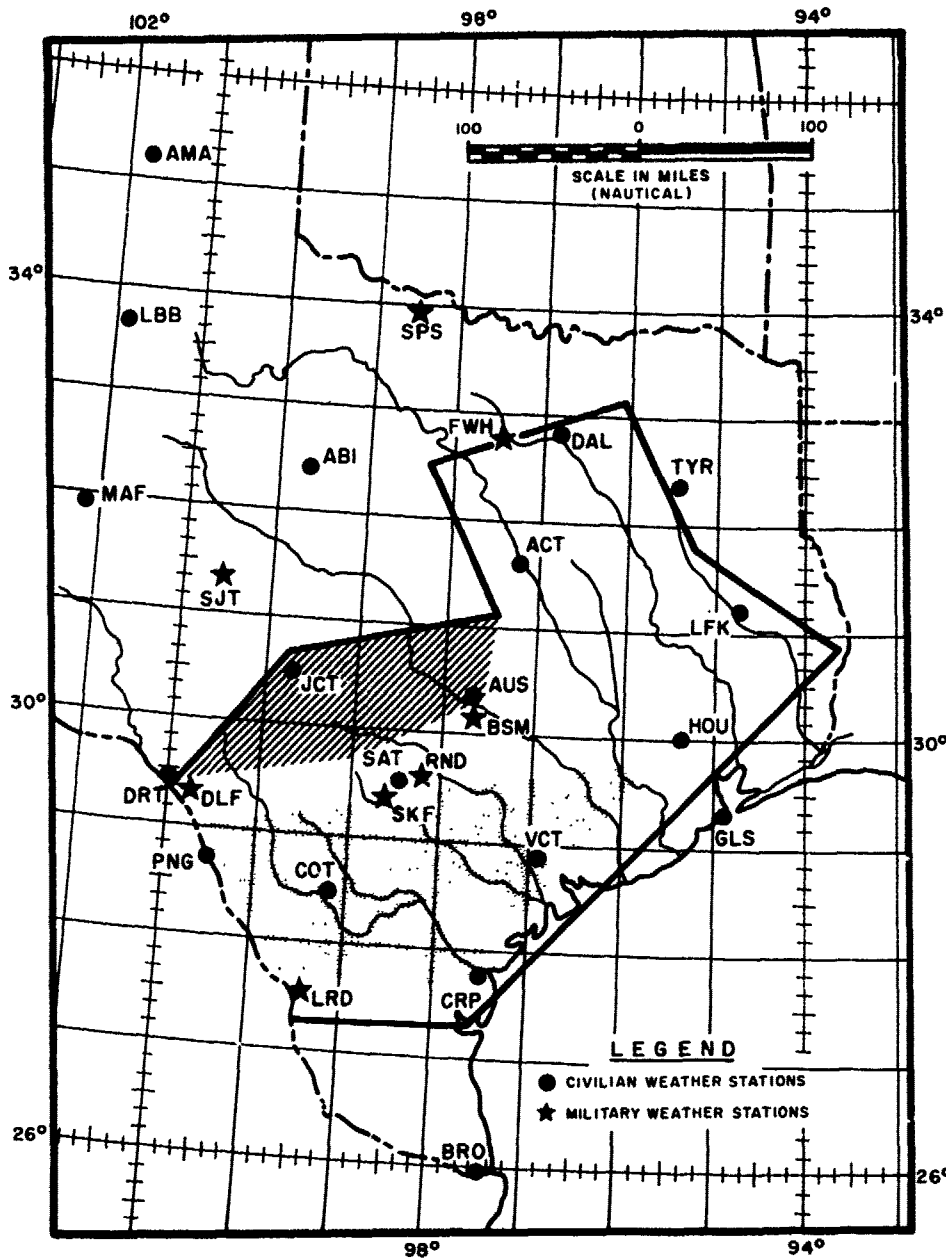

Figure 14. Project COLD RAIN Operating Area. The primary, most intensively seeded area is stippled. The area seeded jointly with BuRec contractors is hatched.

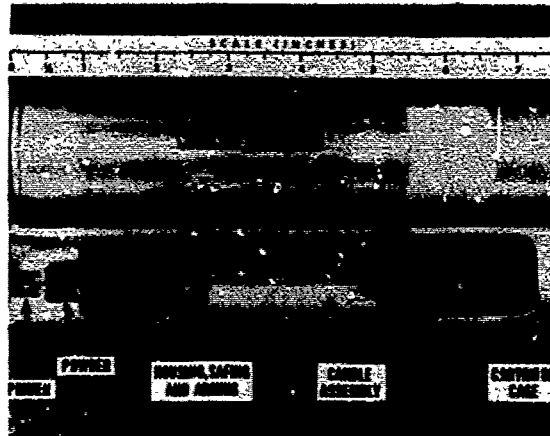

Figure 15. The WMU-1 (XCL-4) Catalyst Generator Developed by the Naval Weapons Center. This pyrotechnic unit emits 25 grams of nucleating silver iodide smoke as it burns through a free-fall depth of 6000 to 8000 feet.



Figure 16. The Flare Racks with Three Baskets in a "Down" Position Ready for Loading.

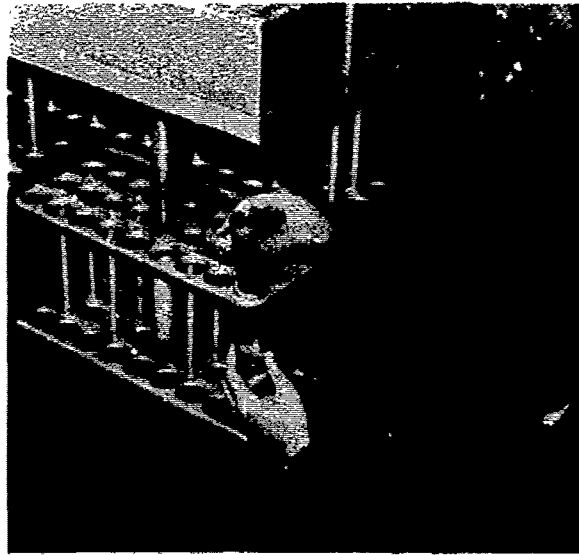

Figure 17. Installation of the Flares.

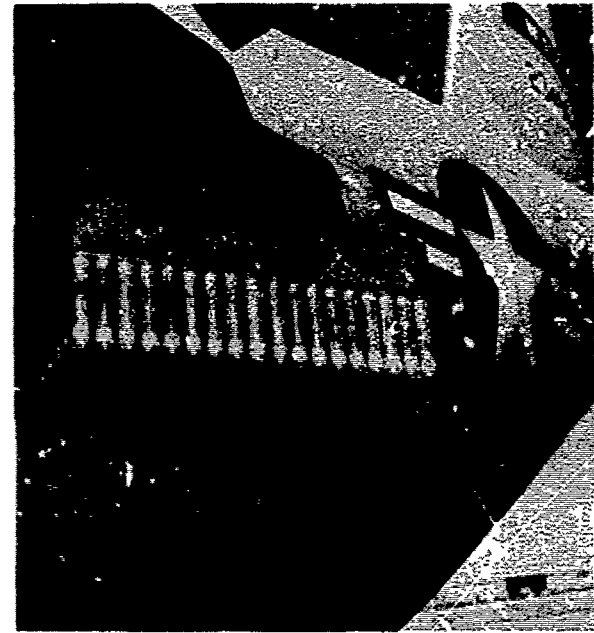

Figure 18. The Ready-To-Fly Project. Each side of the aircraft contains four baskets, each holding 26 flares, for a total capacity of 208 flares per seeding mission.

The WMU-1 (XCL-4)/B catalyst generator (Figure 15) developed by the Naval Weapons Center was the cornerstone of the project. The pyrotechnic cloud-seeding material, pressed into a plastic-covered candle assembly and housed inside a 40-mm aluminum photoflash cartridge, was formulated to burn for about 40 seconds while emitting nucleating silver-iodide smoke through a free-fall depth of 6000 to 8000 feet. The flares were carried externally in baskets

attached to racks mounted on the aircraft's air-deflector doors. Figure 16 illustrates the racks and three baskets in a "down" position ready for loading. The flares are installed as shown in Figure 17, and the final, ready-to-fly product appears as shown in Figure 18. With each basket carrying 26 flares and the usual configuration of four baskets to each side of the aircraft, the total pyrotechnic capacity on each seeding mission was 208. The racks contain firing heads wired to the ATO switch near the co-pilot's position in the cockpit. When the electrical connection is made, the flare ignites ejecting the candle assembly from the aluminum canister which remains fixed in the basket. At the end of its burn time, the candle is completely consumed and nothing reaches the ground.

Weather radar was a primary tool: (1) for deciding which sections of the south Texas target area were developing clouds suitable for seeding; (2) for guiding the seeding aircraft to the proper cloud formations; and (3) for evaluating the degree of success achieved from the seeding effort. The Kelly AFB CPS-9 (3-cm radar) provided nearly continuous coverage during the duration of the project, while FPS-77 (5-cm radars) from Randolph (RND), Bergstrom (BSM), Laredo (LRD), Laughlin (DLF), and Carswell (FWH) Air Force Bases were utilized for specialized coverage when seeding was conducted in those areas. Good pilot-to-forecaster communications enabled the radar technicians to know when and where the seeding aircraft was working. PPI-scope polaroid photographs were taken approximately once every 15 minutes while seeding was in progress. Figure 19, a photograph taken from the Kelly radar, shows the degree of resolution possible. The arrow points to the cloud group being worked by one of the seeding aircraft. The scope is on the 75-mile range with the range mark at 47 statute miles. The return in the center of the picture is ground clutter. At the time the picture was taken, an adjoining RHI radarscope indicated a top of 23,000 feet for the tallest portion of the seeded cloud mass.

The process of deciding the best location within the target area for conducting seeding operations was aided by the results from one-dimensional steady-state numerical convection models. Using as input the 1200Z radiosonde temperature and humidity data obtained from National



Figure 19. Photograph of the Kelly AFB CPS-9 PPI Radarscope Taken During a Seeding Operation on 15 June. The arrow points to a cloud mass being worked by one of the aircraft. The range mark is at 47 statute miles. An adjoining RHI scope indicated a cloud-top height of 23,000 feet for the seeded cloud mass.

Weather Service stations at Del Rio (DRT), Victoria (VCT), Brownsville (BRO), and Midland (MAF), and from a special Air Weather Service mobile balloon unit at Kelly AFB (SKF), the model was able to predict quantitatively the effect of seeding on cloud development. The areas for which the model predicted good "seedability" (a measure of the cloud growth likely to occur from seeding) and in which supercooled cumulus clouds were already present (as determined from the radar information) were first choices for a rain-augmentation mission. In order to provide useful data for post-analysis, an additional special radiosonde was launched daily from Kelly AFB at 1800Z.

After being briefed on the synoptic conditions by the base weather detachment, the project's technical advisers, in consultation with officials from the Bureau of Reclamation and armed with the numerical modeling results and the latest radar indications, determined the number of aircraft to fly as seeders (none, one, or two), the time of launch (usually 1830Z), the advisability of requesting RB-57F high-altitude photography for evaluation purposes, and the regions within the overall target area in which to concentrate seeding activities. The above decisions were generally available to the air crews by 1600Z.

The seeding procedure followed was similar to that used by National Oceanic and Atmospheric Administration (NOAA) scientists in Florida. Cumuliform clouds are judged eligible for seeding if their tops are in the temperature range -4°C to -20°C (generally corresponding to altitudes between 17,500 and 25,000 feet) with the cloud body extending through a depth of at least 10,000 feet. Cumuli with a hard, cauliflower appearance, indicative of a "wet" cloud in a developing stage, are prime targets, while those with a diffuse, wispy appearance, indicative of a "dry" or glaciated cloud in a dissipating stage, are rejected. The most ideal seeding conditions occur when a large "cumulus congestus" cloud mass continuously develops new "hard" supercooled turrets on its upshear side. Seeding the upshear towers as they develop enlarges and better organizes the attending mesoscale circulation which should, theoretically, lead to significantly enhanced localized rainfall.

Usually, the aircraft, flying at a pressure altitude varying between 17,500 and 19,000 feet, penetrated the target cloud turret anywhere from 500 to 2000 feet below its top. If the turret was found to be sufficiently "wet" and/or was found to contain a significant updraft, one flare was released about every two to three seconds while the aircraft was in the updraft region. Generally, the flare expenditure per seeding penetration varied between three and twelve. Occasionally, if the opportunity presented itself, one or two flares were released from 500 to 1000 feet over the tops of rising cumulus turrets. It was found, in some instances, that if the WC-130 aircraft passed within about 500 feet of the turret top, either above or below, the wake entrainment of the drier environmental air had a deleterious effect on the cloud's subsequent development.

Figure 20, a photograph taken during the COLD RAIN operation, illustrates

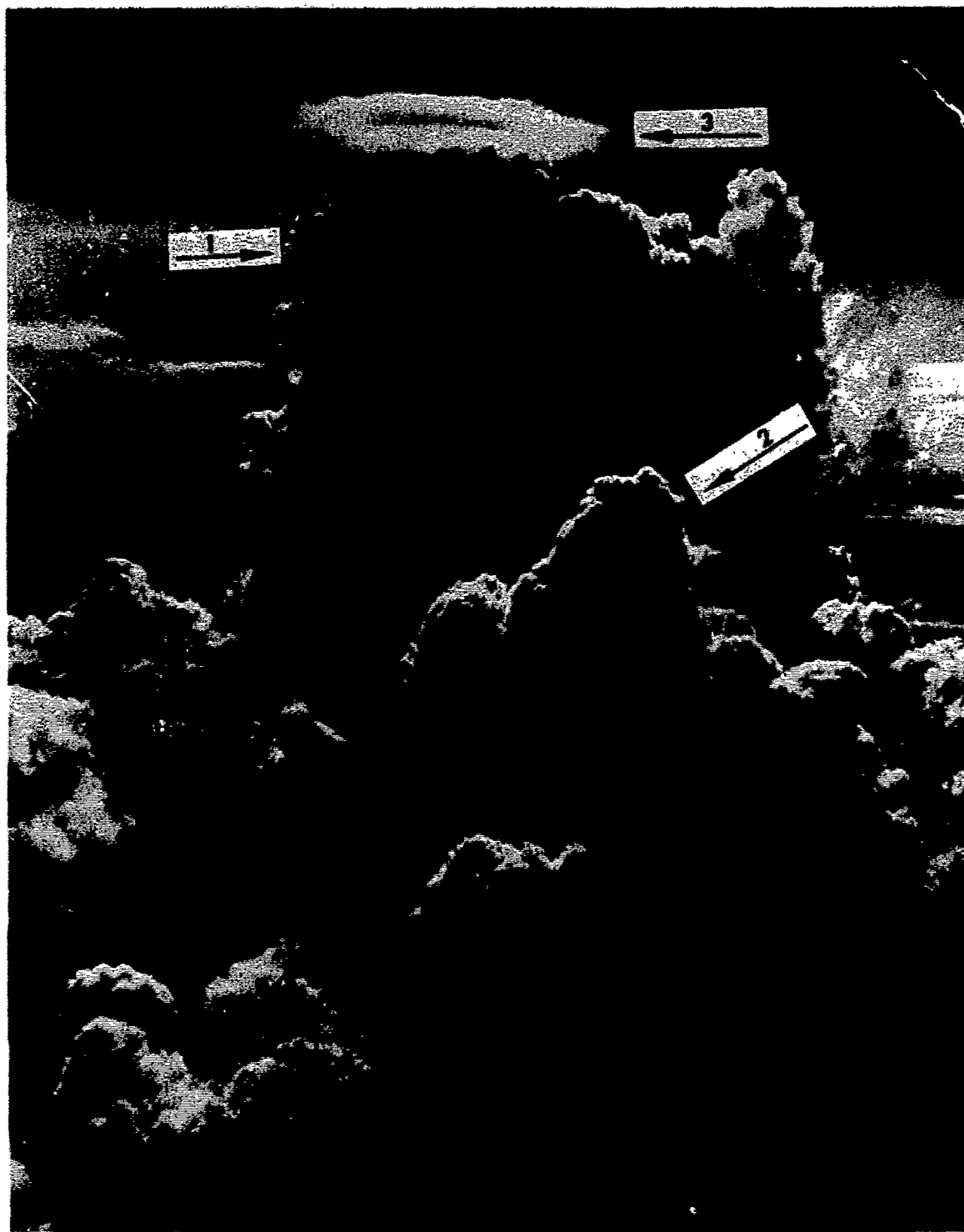

Figure 20. Spectacular Cloud Development Followed Seeding Operations on 12 June. At the time of seeding, about 20 minutes prior to the time of this photograph, the target cloud complex (1) was only the same size as the towering cumulus (2) in the foreground. The pileus cap (3) is a good indicator of vigorous cloud development.

the type of spectacular cloud development which the theory predicts seeding should cause under favorable environmental conditions. At the time it was first seeded, approximately 20 minutes prior to the time of the photograph, the target cloud (1) was only about the same size as the towering cumulus cloud (2) in the foreground. The pileus cap (3) is caused by the cloud turret growing so rapidly that upward motion is induced in the air immediately ahead of it. Because such a cap indicates vigorous cloud development, it is a good evaluative tool for visualizing any immediate effects from the seeding activities. A first subjective estimate is that about 20% of the clouds seeded in the COLD RAIN operation displayed evidence of such vigorous development following seeding.

In answer to the question of whether the COLD RAIN seeding activities increased the rainfall in south Texas, the best reply that we can give is that we feel some clouds were caused to precipitate more efficiently than they would have naturally. Therefore, on some days, certain localized sections of the target area received significant benefit from the seeding activities. The problem is that the natural rainfall which occurred within the target area during the operation was intensive and extensive enough to mask any contribution directly attributable to the seeding. Without a dense rain-gauge network and calibrated precipitation radar, neither of which was available to the operationally-oriented COLD RAIN project, an accurate, quantitative, scientifically-acceptable assessment of the relationship between seeding and rainfall cannot be attempted. A more detailed discussion of the results of the COLD RAIN operation can be found in AWS Technical Report 245 [5].

REFERENCES

- [1] Hq AWS (VPS): A Summary of Field Activities Conducted under MAC Operational Test Order 4-5-69, COLD WAND Final Report, April 1970.
- [2] AWS Technical Report 247 (in preparation).
- [3] 11th Weather Squadron: "Operation COLD COWL - Fiscal Year 1971 - Final Report," Elmendorf AFB, Alaska, 15 March 1971, 7 p plus attachments.
- [4] 31st Weather Squadron: "On-Site Project Coordinator's Final Report (Project COLD CRYSTAL)," APO New York 09012, 9 April 1971, 8 p plus attachments.
- [5] Sax, Robert I. and Cress, Ted S.: "Final Report - Project COLD RAIN," Technical Report 245, Air Weather Service, Scott AFB, Illinois, 47 p. 1971.
- [6] Simpson, J., Woodley, W. L., Miller, A. H., and Cotton, G. F.: "Precipitation Results of Two Randomized Pyrotechnic Cumulus Seeding Experiments," J. Appl. Meteorol., Vol. 10, 1971, pp. 526-544.
- [7] Simpson, J. Brier, G. W., and Simpson, R. H.: "Stormfury Cumulus Seeding Experiment 1965: Statistical Analysis and Main Results," J. Atmos. Sci., Vol. 24, 1967, pp. 508-521.
- [8] St. Amand, P., Reed, D. W., Wright, T. L., and Elliot, S. D.: "Gromet II; Rainfall Augmentation in the Philippine Islands," Naval Weapons Center Report TP 5097, 1971, 110 p.

UNCLASSIFIED

Security Classification

DOCUMENT CONTROL DATA - R & D

(Security classification of title, body of abstract and indexing annotation must be entered when the overall report is classified)

1. ORIGINATING ACTIVITY (Corporate author) Hq Air Weather Service Scott AFB, Illinois 62225		2a. REPORT SECURITY CLASSIFICATION Unclassified	
		2b. GROUP	
3. REPORT TITLE Fourth Annual Survey Report on the Air Weather Service Weather-Modification Program [FY 1971]			
4. DESCRIPTIVE NOTES (Type of report and inclusive dates)			
5. AUTHOR(S) (First name, middle initial, last name) Herbert S. Appleman Capt Laurence D. Mendenhall Capt John C. Lease Lt Robert I. Sax			
6. REPORT DATE April 1972		7a. TOTAL NO. OF PAGES 24	7b. NO. OF REFS 8
8a. CONTRACT OR GRANT NO.		9a. ORIGINATOR'S REPORT NUMBER(S) Air Weather Service Technical Report 244	
b. PROJECT NO.		9b. OTHER REPORT NO(S) (Any other numbers that may be assigned this report)	
c.			
d.			
10. DISTRIBUTION STATEMENT Approved for public release: distribution unlimited.			
11. SUPPLEMENTARY NOTES		12. SPONSORING MILITARY ACTIVITY Hq Air Weather Service (MAC) Scott AFB, Illinois 62225	
13. ABSTRACT This annual report on the weather-modification activities of the Air Weather Service discusses the techniques, procedures, and results of the projects undertaken during FY 1971. Its primary purpose is to inform AWS field personnel on the weather-modification progress enjoyed during the year. Detailed reports of the individual projects are published elsewhere when warranted. COLD WAND, COLD FLAKE, COLD COWL, COLD CRYSTAL, WARM FOG, and COLD RAIN are the activities covered in this report.			

DD FORM 1473
1 NOV 65

26

UNCLASSIFIED

Security Classification

S AFB, IL 72-22892